

# PROTECTOR P70 MANUAL 2022



WWW.IWTM-UK.COM  
T: +44 208 255 2903  
E: INFO@IWTM-UK.COM

# TABLE OF CONTENTS

03	DESCRIPTION & FEATURES
05	INSTALLATION
08	DATA & MEASUREMENTS
10	MAINTENANCE
16	ACCESSORIES
17	VALVE KIT
18	SERVICE JOURNAL

# DESCRIPTION & FEATURES

## WHAT IS PROTECTOR P70?

Protector P70 is a model from our IWTM Protector™ range, a unique side stream filtration device that engineers the system water to a non-corrosive state. It provides corrosion protection in both new and existing heating and cooling systems, by removing sludge, particles, oxygen and other corrosive products. Therefore the system is maintained in the best possible way, by constantly filtering and engineering the water using electrochemistry and anode technology. The result is that its cleaning and engineering the water at the same time.

## NEXT GENERATION OF ELECTROCHEMISTRY

The units provide faster clean-up of old systems and quicker compliance with pre commissioning targets on new systems due to the higher flow rates through the reaction tank (cathode) and the inbuilt strainer basket that enables finer filtration. The unscreened larger anodes last longer and release the magnesium hydroxide quicker for faster pH control. Compliance with VDI 2035 is still obtained as the anodes sit inside the basket to capture the magnesium residue when the anodes expire.

- Protector is an "all in one solution"
- Controls the three key parameters of VDI 2035 ; pH, conductivity & dissolved oxygen.
- Creates a hostile environment for bacteria
- Keeps the water clean in closed circulation systems and removes all particles and impurities

In closed systems typical installation will be in side stream but it can also be installed in the main flow in a modular arrangement for larger systems. This provides a method of easy installation, operation and maintenance.

## PARTICLE FILTRATION

Protector P70 comes as standard with a robust stainless steel filter which is 40 micron nominal (55 absolute) . The stainless steel AISI 316, 55µm filter has a large surface which gives a long operating time before cleaning and thus less flushing and refilling.

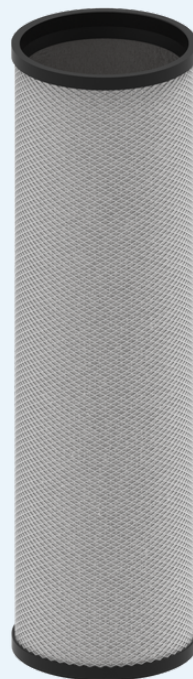

**2-Layer S.S Filter**

# DESCRIPTION & FEATURES

## NEODYMIUM MAGNETS

One long, dry, powerful magnet is mounted in the centre of the filter and in front of the sacrificial anodes so that magnetite is captured and not deposited on the anodes, also preventing the filter basket from clogging up with magnetite. This provides longer service intervals as well as increased operational life and better function. When the magnet is lifted out, all magnetite will be released and can be drained out.

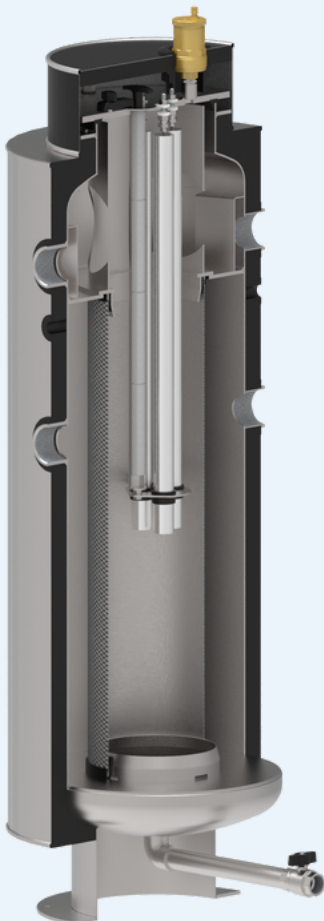

## SACRIFICIAL ANODES

Magnesium anodes that provide anodic water treatment and lower the fluid's conductivity.

The anodes also scavenge oxygen and regulate the pH level.

For longer life expectancy, the anodes are encapsulated by a stainless steel filter basket, removing the need for individual anode screens.

# INSTALLATION



For larger volume systems, installation in series is possible.

## SIDE STREAM INSTALLATION

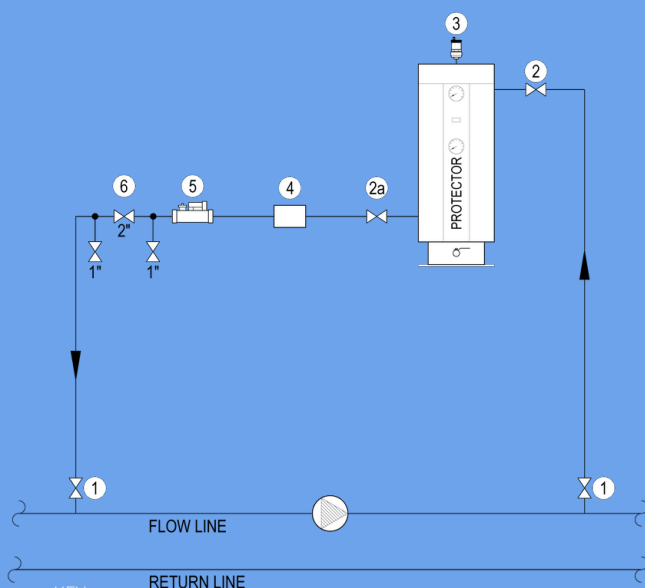

- KEY**
- 1. CLIENT IV's NOT SUPPLIED
  - 2. DRAIN COCK LEVER IV MALE & FEMALE
  - 2a. LEVER IV MALE & FEMALE
  - 3. 551 CALEFFI UNIT AIR VENT
  - 4. MECHANICAL WATER METER
  - 5. FLOW REGULATOR
  - 6. FLUSHING BY-PASS FOR PUROTAP LEADER

Protector P70 is to be mounted in a "bypass" installation over an existing circulation pump. (Separate circulation pump can be used if needed.)

- Pressure side on pump should be to the inlet on Protector P70 unit.
- Suction side on pump should be to the outlet on Protector P70 unit.

## INSTALLING CONNECTIONS

- 2 pc 1" Female Connections (inlet / outlet)
- 2 pc 2" Plugs (for connections not in use.)
- 2 pc 2" Ball valves
- 2 pc 2" Plugs
- 1 pc 2" Flowmeter
- 1 pc 2" Regulating Valve
- 1 pc 1/2" Air Vent
- 1 pc 2" Drain Valve
- 1 Test Point Valve



# INSTALLATION

## SIDE STREAM INSTALLATION USING OWN PUMP

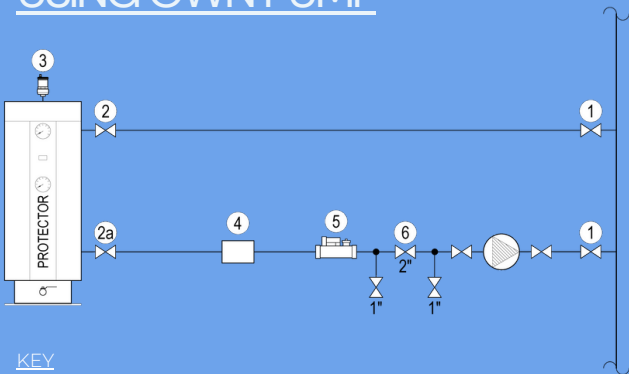

KEY

- 1. CLIENT IV's NOT SUPPLIED
- 2. DRAIN COCK LEVER IV MALE & FEMALE
- 2a. LEVER IV MALE & FEMALE
- 3. 551 CALEFFI UNIT AIR VENT
- 4. MECHANICAL WATER METER
- 5. FLOW REGULATOR
- 6. FLUSHING BY-PASS FOR PUROTAP LEADER

Connections:

Can be connected:

- IN from either left or right. (only on the top)

-OUT from left or right. (only on the bottom)

-Connections not in use, to be plugged.  
(1" female threads)

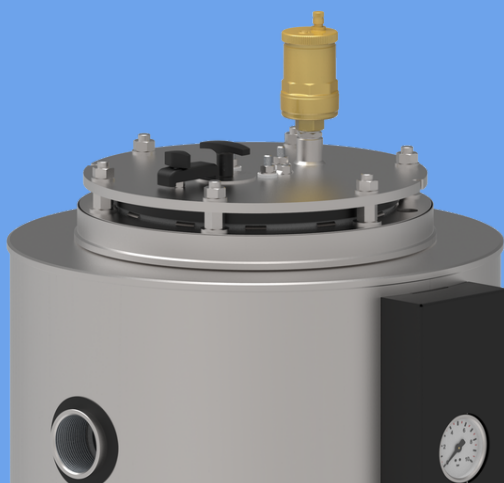

# INSTALLATION

## INSTALLATION & COMMISSIONING INSTRUCTIONS

- Close the outlet valve.
- Keeping outlet closed whilst opening the inlet valve.
- Open the automatic air vent.
- Fill the Protector unit the automatic air vent has dispensed all of the air.
- Open the outlet valve so water flows through the Protector.
- Check the water meter is rotating.
- Set regulating valve as below:

### Isolation and Flow Regulation:

The valve can be operated from fully closed to fully open..

A slot on the end of the control stem indicates the status of the valve.

When the control stem is turned fully clockwise and the slot lies perpendicular to the axis of the valve, the valve is fully closed.

When the control stem is turned fully anti-clockwise and the slot lies in line with the axis of the valve, the valve is fully open.

**altecnic**  
CALEFFI group

Closed      Fully Open      Partly Open

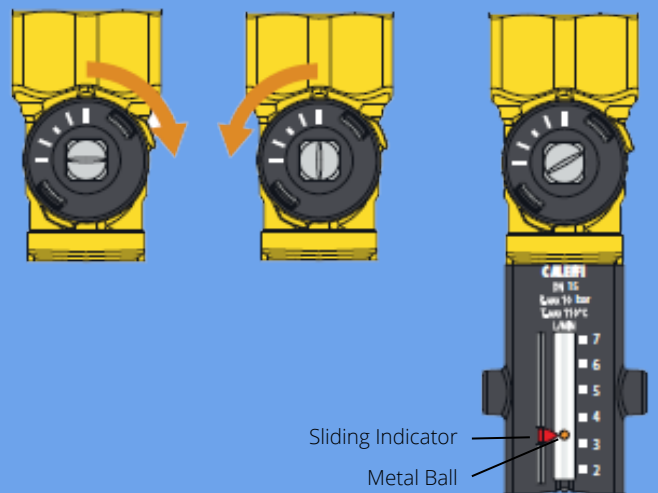

To regulate the flow, firstly with the aid of the sliding indicator, mark the reference flow rate to which the valve requires setting.

Using a suitably sized spanner on the operating square of the control stem of the valve rotate until the design flow rate is achieved.

This is indicated by the metal ball that runs inside the transparent guide.

- Record the water meter reading

# DATA & MEASUREMENTS

## PROTECTOR P70 DATA

**System Volume:** Heating -Max. 70m<sup>3</sup>

Cooling - Max 60m<sup>3</sup>

**Flow:** 70l/min

**Empty Weight:** 88KG

**Full Weight:** 218KG

**Shipping Weight:** 157KG

-----  
**Design Pressure** – PN10

**Max Temperature** – 95°C

**Volume of Unit** – 130L

**Design Code** – PED 2014/68/EU

**Connection** – 2" female thread / BSP

## MATERIALS

**Filter House:** Stainless steel AISI 304

**Filter Element:** Stainless steel AISI 316L

**Gasket:** EPDM

**Insulation/Mantling:** Armaflex

/stainless steel

**Manometer:** Stainless steel AISI 304

**Anodes:** Magnesium with filter AISI 304

**Magnet:** Neodymium

**Surface treatment:** Brushed Stainless Steel

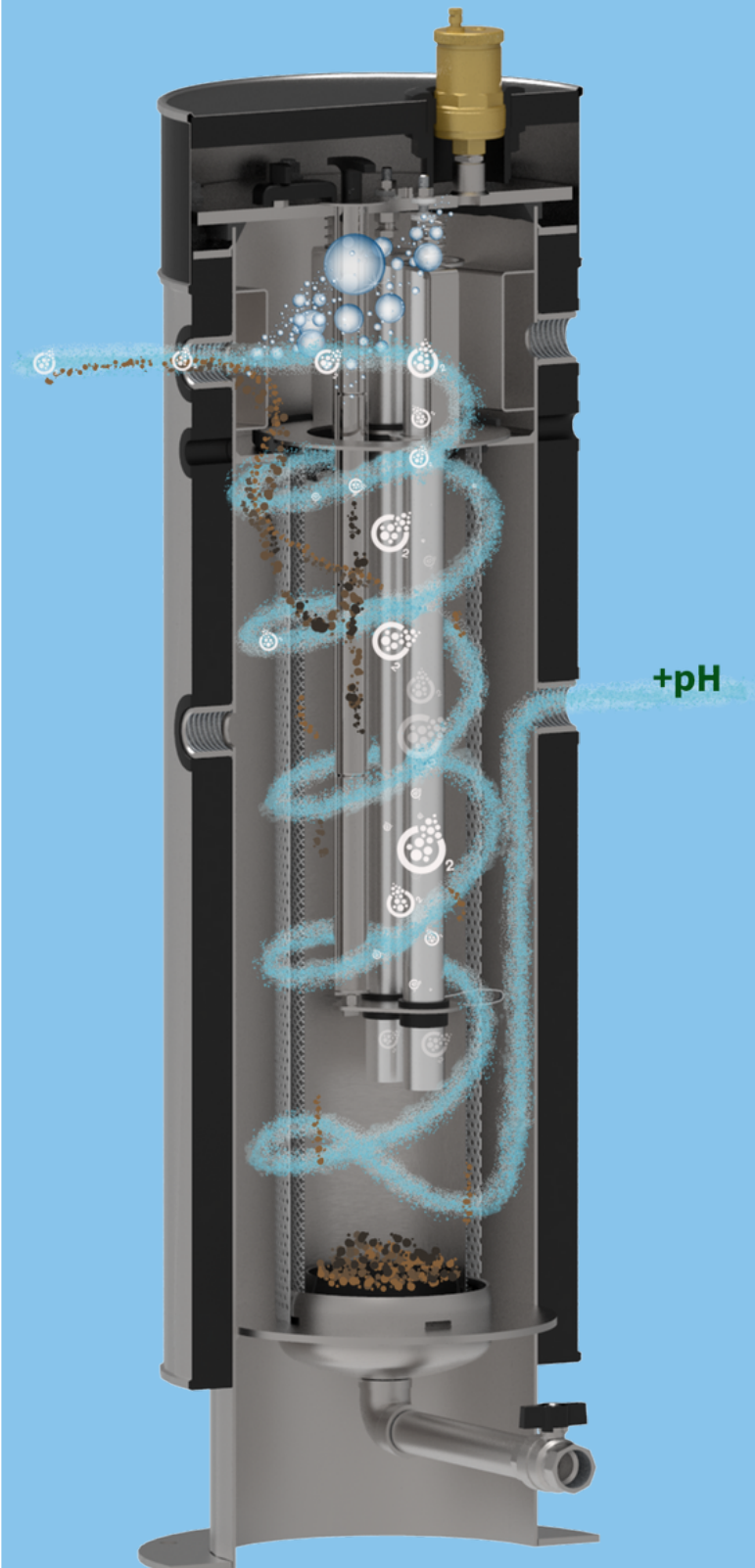

**Note:** Talk to us for systems that operate at higher pressures or higher temperatures.



# DATA & MEASUREMENTS

## PROTECTOR P70 MEASUREMENTS

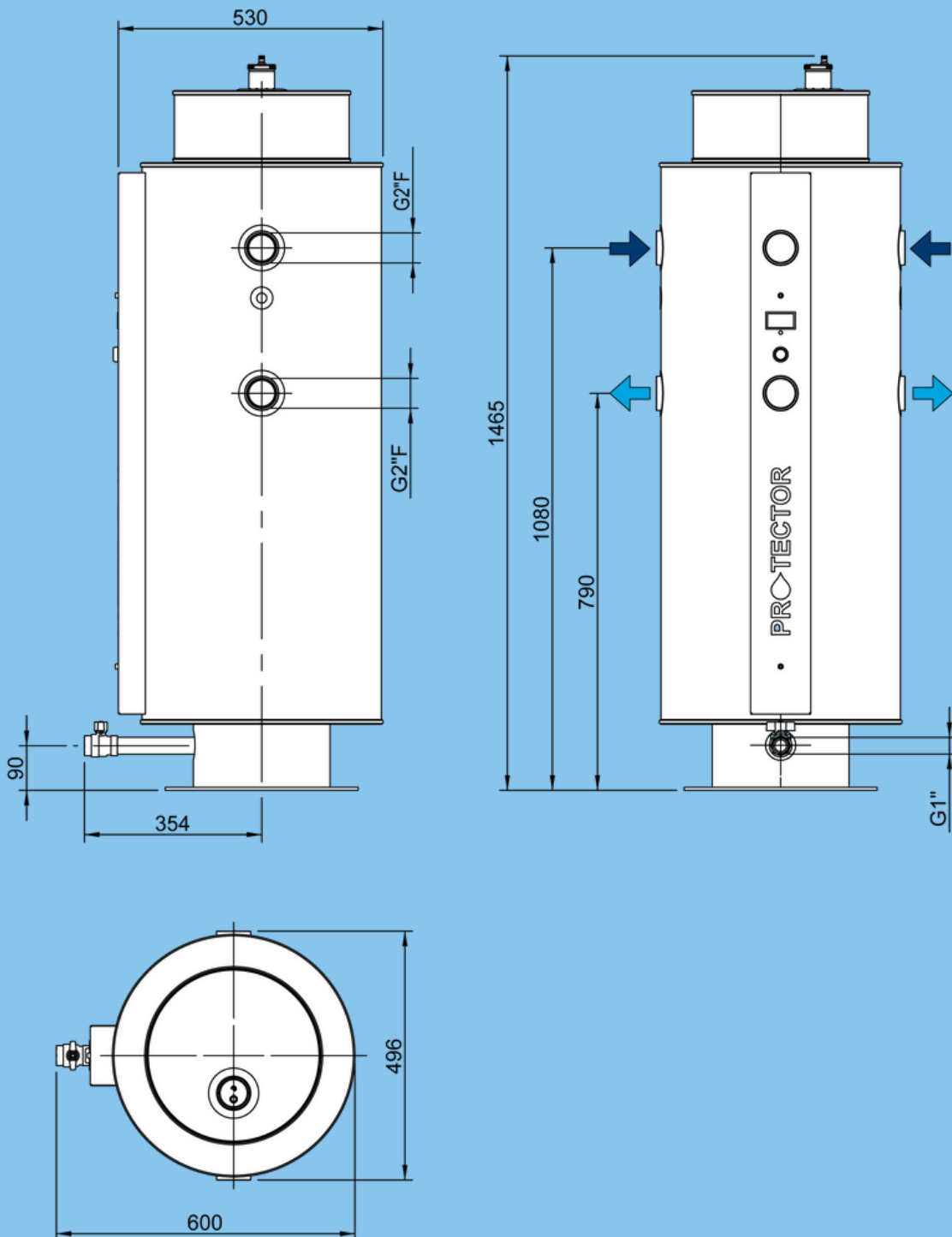

# MAINTENANCE

## DRAINING

The Protector P70 unit needs to be drained frequently ; how often is dependent on the water quality.

The higher the starting conductivity level, the more sludge there'll be, resulting in a need for more frequent draining.

This is to flush out the sludge and particles that have been collected in the bottom of the tank, from the magnet trap and the strainer.

The one piece long magnet in the Protector P70 is inserted on top of the tank on the flange lid.

- Close the inlet to the Protector P70.
- Pull out the magnet on top of tank.
- Open the drain valve in the bottom of tank and flush until the water is running clear of debris.
- When complete, close the drain valve and put the magnet back in the sleeve.



# MAINTENANCE

## ANALOGUE GALVANOMETER & PUSH BUTTON

The analogue galvanometer shows the galvanic current in milliamps between the anodes and the cathode (the tank body), with the system water being the medium.

The analogue galvanometer is always in a continuous reading position ; when the switch is pressed, the instrument is short circuited and shows little or no reading. This function is only for testing the analogue meter itself.

Pure water is non conducting, therefore the more impurities and oxygen in the water the more current will flow between the anode and the cathode.

When the water quality improves, the current diminishes and may measure even as low as 0.2 to 0.3 milliamps when the system water is fully passive.

The Protector P70 system is self-regulating, the anode automatically works harder with corrosive water than with water that is no longer reactive.

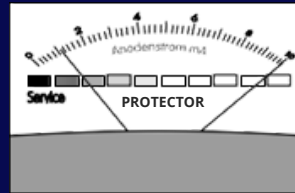

The needle swing lies between 10% and 100%.

This is the normal operating region. The lower the reading, the less the anode needs to work, and the less impurities are in the system water.

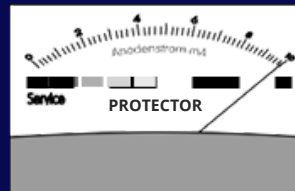

The needle always reads 100%.

The anode is working hard.

If the needle remains in this position for longer than one heating season, the Protector P70 may be undersized for the system.

Action: check the system volume

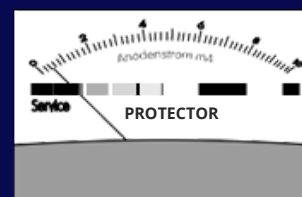

The needle lies continuously close to the red region ; the needle still drops

to the minimum reading when you press the test button however, the anode no longer needs to work because the chemical reactions in the water have finished, or the anode can no longer work because it is coated in a barrier layer...

# MAINTENANCE

## ANALOGUE GALVANOMETER & PUSH BUTTON

Action: remove the sludge from the Protector P70 and fill with fresh water. Keep the isolation valves closed for a day to hold the more corrosive fresh water inside the Protector P70.

After a day, if the operating meter shows a higher reading, everything is operating correctly, and the Protector Master can be put back into operation. Otherwise, you need to open the lid to inspect the appliance.

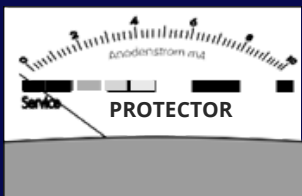

**The needle drops into the red region within a few weeks.**

The anode is spent or coated in a barrier layer or the Protector Master is isolated from the system and no water is circulating through it.

Action: check circulation or open the appliance and clean or replace the anodes.

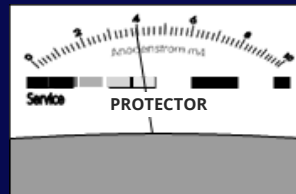

**The meter continues to show a constant reading over a long period.**

The operating meter might be faulty.

Action: press the test button to check the meter (the needle should drop to the left).

**If there is no change in the needle position, the meter is probably faulty.**

While the Protector P70 is increasing the pH and scavenging oxygen the water gets less aggressive and the current will decrease and stabilise. (normally from 4-15 mA). If some chlorides or sulphates should interfere, resulting in higher conductivity or increased oxygen (feed water), the ampere & output will increase again.

# MAINTENANCE

## MAGNESIUM ANODES

The filter anodes are in a basket of stainless steel wire mesh called the anode intensifier and do not need any cleaning. Check the anodes for proper functioning (mA instrument)



## TOOLS:

- Isolating screw dry side 13 mm spanner
- Isolating screw wet side 17 mm spanner
- Anode screw 10 mm spanner
- Flange cover 19 mm spanner

## SERVICE

Service on the Protector P70 unit should be done once a year. However, this is also depending upon the quality of the system water.

If there has been an existing problem with sludge, sediments etc. before the Protector P70 installation, we recommend a first service after 3 months of operation.

It's also important to take a water sample out of the system, for analysis in a laboratory.

The isolation screw going through the flange has two TeFlon washers on both sides of the flange. Once opened, they **cannot** be reused. These washers are not part of the replacement kit. So don't open the isolation screw.

# MAINTENANCE

## SERVICE

- Close the inlet and outlet ball valves.
- Unscrew the air vent and empty the tank through the drain valve.
- Unscrew the flange lid.
- Carefully lift up the lid, the anodes are attached to the underside.
- Check the anodes and the magnesium rods.
- Flush the anodes, if the magnesium is below 10mm diameter, replace with new ones.
- Take out the strainer and flush / clean.
- Clean the tank inside using a hose or a pressure gun.
- Check all parts belonging to the Protector Master and clean them if required. (AAV flowmeter, reg. Valve etc.)

When replacing the anode hold the isolation screw going through the flange and unscrew only the small inner screw at the end of the steel core of the anode. After mounting a new anode, make sure that all screws are tight and that the electrical wiring is properly reinstalled. If there's no indication on the meter, the Protector P70 is not working.

When done, put everything back in place and fill up the Protector P70 on the inlet. When the air vent stops letting out air, the tank is refilled and you can open the outlet and start the circulation again. Check that the flowmeter is running.

1)

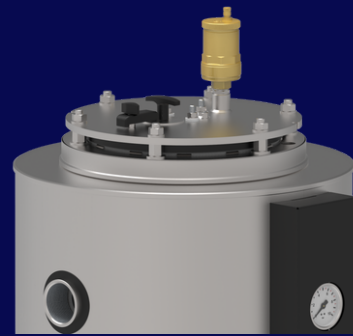

2)

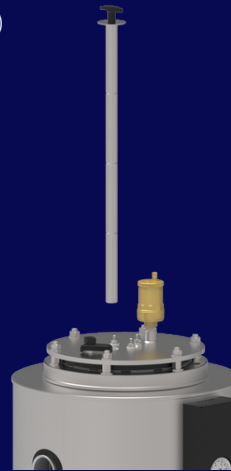

3)

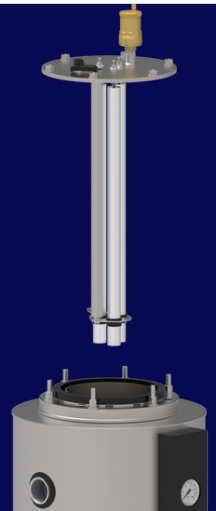

4)

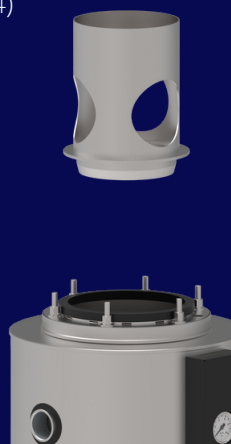

5)

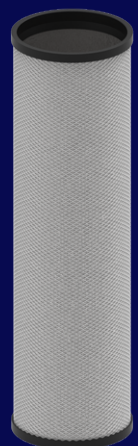

# MAINTENANCE

## PARTICLE FILTER

Inside the Protector P70 unit is installed a strainer filter, to catch and remove all sediments and particles.

- The filter is locked with a small metal clip in the bottom.
- Just twist the filter slightly to the top left and lift it out.
- Clean the filter with a water hose.
- Make sure all particles are removed from the filter.

When done just put it back, turn it slightly to the right and its locked again.

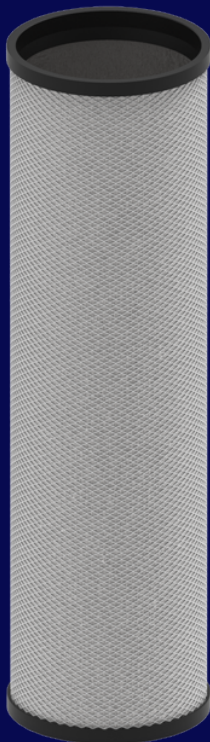

(AISI 316 with  
110µm or 55µm  
filter element.)



# ACCESSORIES

Part No.	Description
<b>Protector - Complete Units</b>	
FZPRBG035	PROTECTOR P70 ANALOG 2" F WITH UK VALVE KIT
<b>Protector - Stainless Steel Strainers</b>	
AMCRT0048	2 LAYER INOX FILTERKIT SIZE 11, 55µm
<b>Protector - Gaskets</b>	
CDGRN0005	VESSEL GASKET Ø273 (EPDM)
<b>Protector - Spare Anodes</b>	
101565	Anodes 1 Set - PROTECTOR P70









# Environmental Culture Change

*be a part of it*

clean | protect | prevent



Founded in 1992, IWTM have been working with chemical free water treatment using electrochemistry for over 30 years and have offices in Norway, UK, Finland, Sweden, Canada, USA and a worldwide presence in the Marine sector.

We have developed models specifically suited to the higher demands of the marine industry operating at higher pressures and higher temperatures. The marine products are provided worldwide on the world's largest cruise ships working with the leading operators in this sector.

Having secured DNV approval in 2003, we are still the only chemical free water treatment manufacturer to have this certification and approval. DNV is a globally leading quality assurance and risk management company operating in more than 100 countries.

The IWTM Protector™ is our most recently developed product. The Protector range is now available to our land-based customers.

Version 2 : December 2022

*In line with continued product development we reserve the right to make any changes to this document without any given notice.*

# PROTECTOR

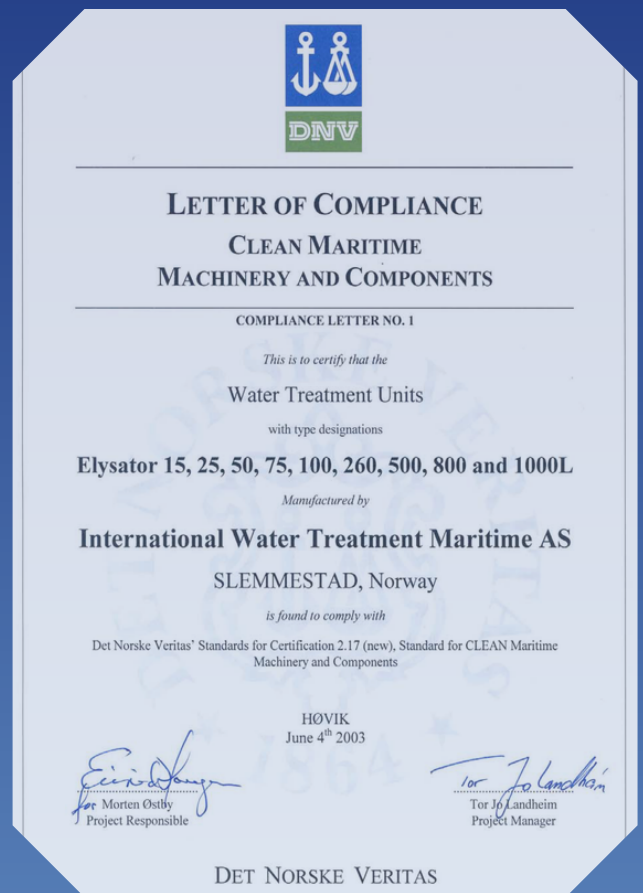

SUTTON BUSINESS CENTRE  
RESTMOR WAY  
WALLINGTON SM6 7AH

WWW.IWTM-UK.COM  
T: +44 208 255 2903  
E: INFO@IWTM-UK.COM