

PROTECTOR

Installation / Service, Master & Mini models



- Alkalization Binder
- Removes oxygen
- Magnetite trap
- Sludge & particle filter

PROTECTOR

What is it?

PROTECTOR:

Is a unique combination water treatment plant that retrieves most of the properties from standard water treatment system.

Protector provides complete corrosion protection in new, old heating and cooling systems, Protector will remove sludge, particles, oxygen and other corrosive elements and corrosion products, so that the system function is maintained in the best possible way.

- Removes impurities
- Protector keeps the water clean in closed circulation systems and removes all particles.
- Protector is an "all in one solution" that will replace most other solutions. Here, all technologies are used in a unit that thus provides extreme functionality, good economy, and operational reliability.

Particle filtration

PROTECTOR comes with a robust stainless steel filter.

Stainless steel AISI 316 with 110µm or 55µm filter.

The filter has a large surface which gives a long operating time before cleaning and thus less flushing and refilling.



2-Layer S.S
Filter

PROTECTOR

Neodymium Magnets:

- Mounted in the centre of the filter and in front of the sacrificial anodes, so that magnetite is captured and NOT deposited on anodes, provides longer service intervals as well as increased service life and better function. When the magnet is lifted out, all magnetite will be released and can be drained out.

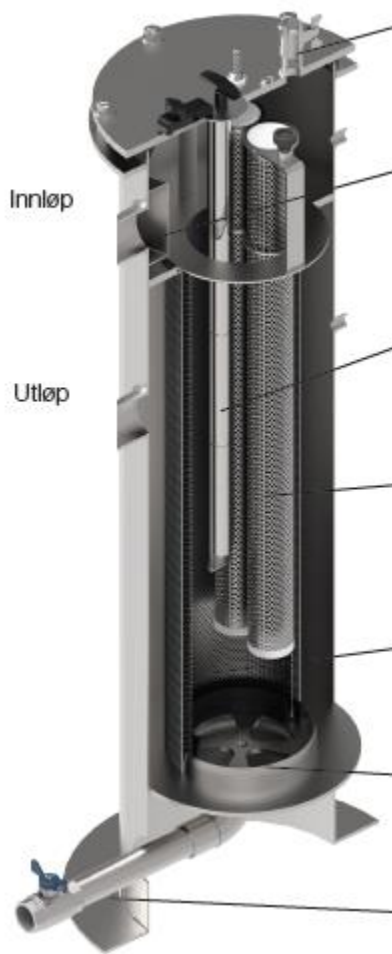

Sacrificial Anodes:

- Magnesium Anodes that provides cathodic protection and lower the fluids conductivity.
- The anodes also scavenge Oxygen and regulate the pH level

PROTECTOR

INSTALLING CONNECTIONS:

2 pc 1" female connections (inlet / outlet)

2 pc 1" plugs (for connections not in use.)

2 pc 1" ball valves

2 pc 1" plugs

1 pc 1" flowmeter

1 pc 1" regulating valve

1 pc 3/8" air vent

1 pc 1" drain valve

Option automatic drain:

2 pc 1" norm closed solenoid valves



FOR BIGGER SYSTEMS, installation in series is possible.

INSTALLATION:

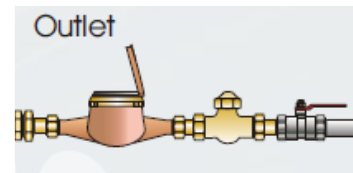
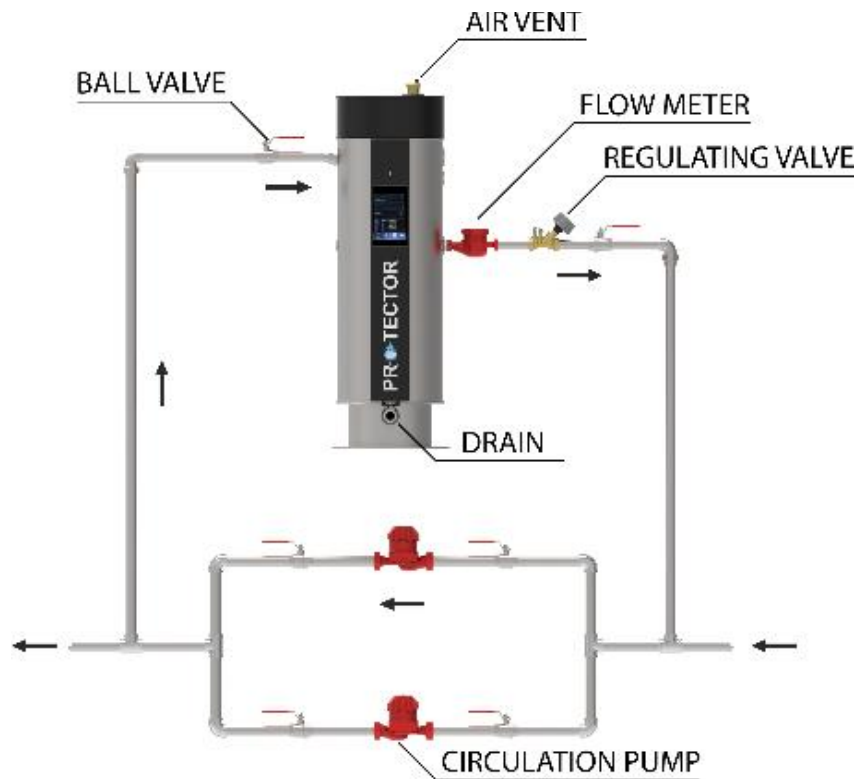

Side stream filtration:

Protector to be mounted in a "Bypass" installation over existing circulation pump.
(Separate circulation pump can be used if needed.)

- **Pressure side on pump to Inlet on Protector unit.**
- **Suction side on pump to outlet on Protector unit.**
- **1-3 % of the flow through the Protector. (See table further down')**
- **Inlet ball valve: Fully open**
- **Outlet: Flow to be regulated through flowmeter and regulating valve.**

Connections:

- 2 pc 1" ball valve inlet/ outlet.
- 1 pc 1" reg. Valve (outlet)
- 1 pc 1" flowmeter (outlet)
- 2 pc 1" plugs (not used connections)
- Make sure of its free space from the top of the Protector. (For Service)
- Protector master – 70CM Protector Mini – 50CM

COOLING INSTALLATION

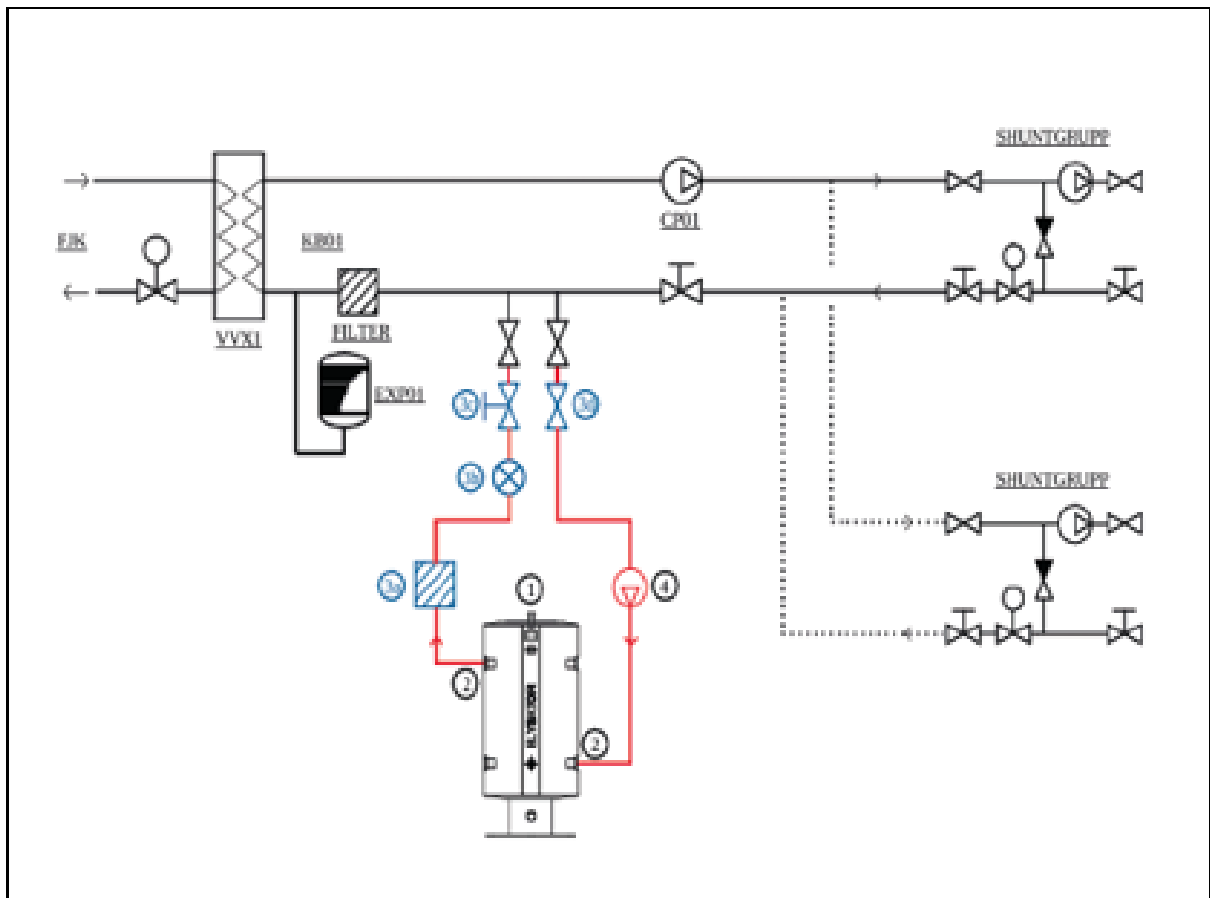

Connections:

Can be connected:

- IN from either left or right. (ONLY ON TOP)
- OUT from left or right. (ONLY ON THE BOTTOM)
- Connections not in use, to be plugged. (1" female threads)

NB:

**Top cover/ flange must be according to the water inlet
(open and adjust accordingly)**

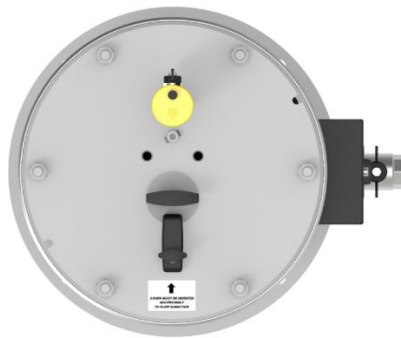

**COVER MUST BE ROTATED
ACCORDINGLY
TO FLOW DIRECTION**

DATA:

Protector Master:

System Volume – Max. 40m³
Flow: 10m³ – 20 l/min
30m³ - 30 l/min
40m³ – 40 l/min

Net: 56KG
Gross: 70KG

Protector Mini:

System Volume – Max. 15m³
Flow:
System Volume: 5m³ – 10 - 20 l/min
10m³ – 20 - 30 l/min

Net:32KG
Gross: 45KG

Design Pressure – PN10
Max Temperature: 95 Celsius
Tank Volume 57L
Design code – PED 2014/68/EU
Connection: 1" female thread / BSPP

Materials:

Filter house – Stainless steel AISI 304
Filter element – Stainless steel AISI 316L

Gasket – EPDM
Insulation / Mantling – Armaflex /stainless steel
Anodes – Magnesium
Anode filter – Stainless steel
Magnet – Neodymium
Surface treatment - Hot-dip galvanized / powder coated

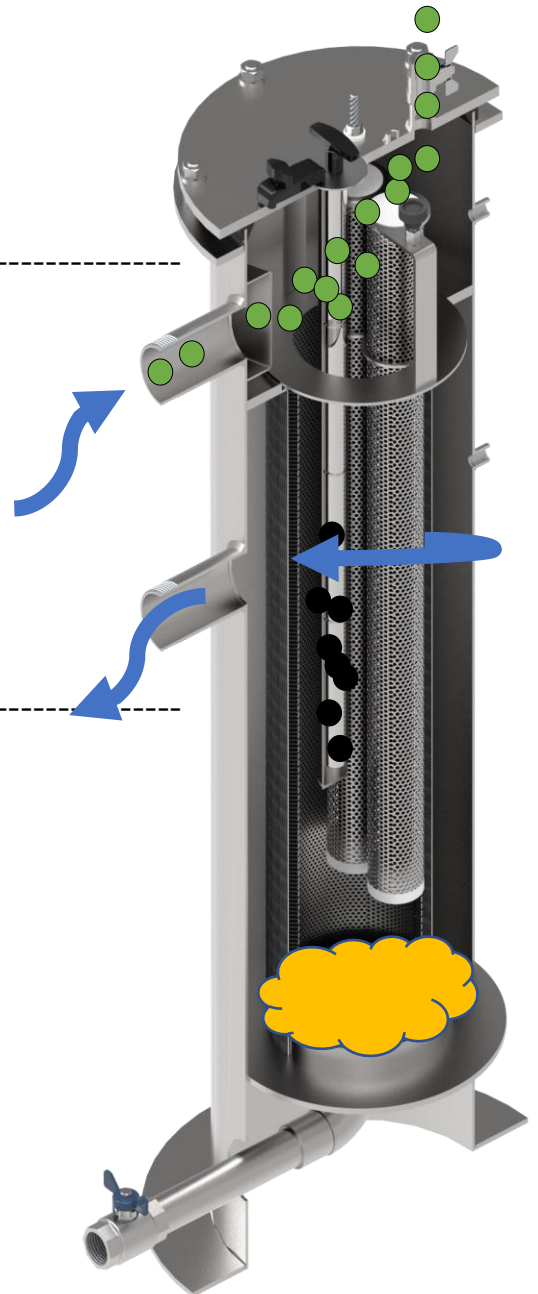

MAINTENANCE:

Draining:

The Protector unit needs to be drained frequently. (how often are depending on the quality of the water)

- Higher conductivity level, more sludge and more frequent draining.

This to flush out the sludge and particles that has been collected in the bottom of the tank, From the magnet trap and the strainer.

- Close inlet to protector.
- Pull out the magnet on top of tank.
- Open drain valve in the bottom of tank and flush until clear water is running.

Magnet (S) are placed on top of the tank, on the flange lid.



(In holsters in through the tank.)

- **Master: 1 PCS long magnet**
- **Mini: 2 PCS shorter double magnets**

When done, close drain valve and put magnet back in the holster.

Analog Galvanometer & Push button



- The analogue galvanometer shows the galvanic current in milliamps between the anodes and the cathode (the tank body), with the system water being the medium.
 - The analogue galvanometer is in a continuous reading position. when the switch is pressed, the instrument is short circuited and shows little or no reading - this function is only for testing the analogue meter itself.
 - Pure water is non conducting.
 - Therefore, the more impurities and oxygen in the water, the more current will flow between the anode and the cathode. when the water quality improves, the current diminishes and may measure even as low as 0.2 to 0.3 milliamps when the system water is fully passive.
 - The Protector system is self-regulating. The anode automatically works harder with corrosive water than with water that is no longer reactive.
 - The needle swing lies between 10% and 100
- This is the normal operating region.*
- The lower the reading, the less the anode needs to work, and the less impurities are in the system water
 - When instrument shows 0, the magnesium anodes inside is most likely consumed. Open the tank and check the anodes, if consumed they will need to be changed.
 - While Elysator is increasing pH and scavenging oxygen the water gets less aggressive and the current will decrease and stabilize. (normally from 4-15 mA). If some chlorides or sulphates should interfere, resulting in higher conductivity or increased oxygen (feed water), the ampere & output will increase again.

PROTECTOR

Magnesium Anodes

- The Filter anodes are in a basket of stainless steel wire mesh, called the anode intensifier, and do not need any cleaning. check anodes for proper functioning (mA instrument)



Close inlet and outlet empty the Protector tank through the drain cock.

Open the lid to the flange and gently unplug the electrical contacts.

- Unscrew the air vent and release the vacuum by pressing the spring in the stop valve; let the water drain out
- Open the flange and pull out the anode together with the flange. check as follows:
- If there is no more magnesium anode left inside the filter, the anodes need to be replaced.
- Tools:
- Isolating screw dry side 13 mm spanner
- Isolating screw wet side 17 mm spanner
- Anode screw 10 mm spanner
- Flange cover 17 mm spanner
- The isolation screw going through the flange has two special washers on both sides of the flange. Once opened, they cannot be reused. These washers are not part of the replacement kit. So do not open the isolation screw. when replacing the anode hold the isolation screw going through the flange and unscrew only the small inner screw at the end of the steel core of the anode. After mounting a new anode, make sure that all screws are tight and that the electrical wiring is properly reinstalled. If there is no indication on the meter, the Protector is not working.

PROTECTOR

SERVICE:

- Service on the Protector unit should be done once a year.
- This is also depending upon the quality of the system water.

If there is a big problem with sludge, sediments etc. before the Protector installation, we recommend a first service after 3 months running.

Important is also to take a water sample out in the system, for analyses on a laboratory.

- Close inlet and outlet ballvalve.
- Unscrew the airvent and empty the tank through the drain valve.
- Unscrew the flange lid.
- Lift up the lid, the anodes are attached to the lid.
- Check the anodes and the magnesium rods.
- Flush the anodes, if magnesium is below 10mm diameter, replace with new ones.
- Take out the strainer and flush / clean it.
- Clean the tank inside using a hose or a pressure gun.
- Check all parts belonging to the Protector and clean them. (Deaerator, flowmeter, reg. Valve etc.)

When done, put everything back in place and fill up the Protector on the inlet, when airvent stops letting out air, the tank is refilled and you can open on the outlet and start the circulation again.

Check that the flowmeter is running.



Particle Filter



2-LAY INOX FILTERKIT

(AISI 316 with 110µm or 55µm filter element.)

Inside the Protector unit it installed a strainer filter, to catch and remove all sediments and particles.

- The filter is locked with a small metal clip in the bottom.
- Just twist the filter slightly top left and lift it out.
- Clean the filter with a water hose.
- Make sure all particles are removed from the filter.
-

When done just put it back, turn it slightly to the left and its locked again

PROTECTOR

PROTECTOR MASTER MEASURES

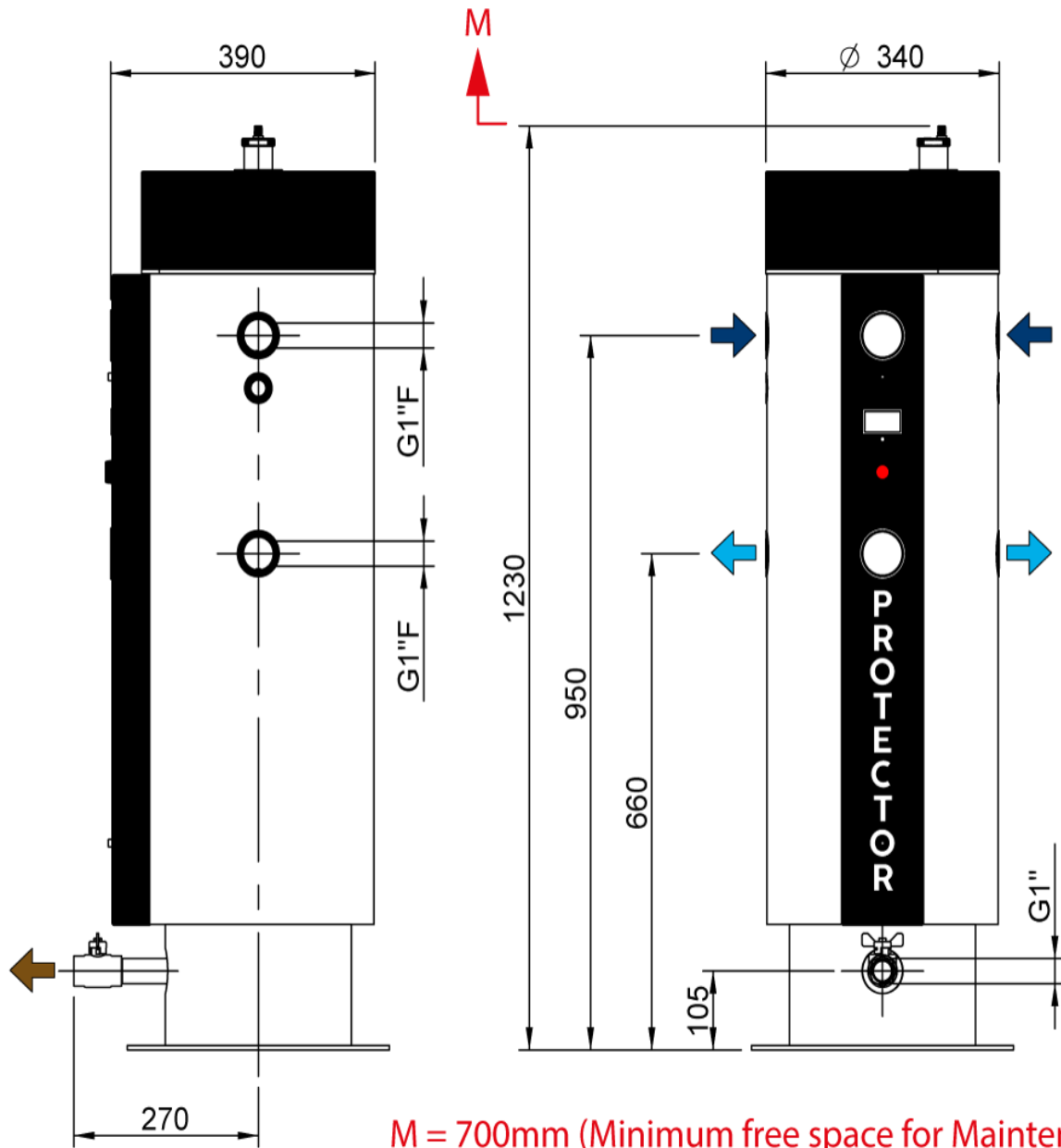

PROTECTOR

PROTECTOR MINI MEASURES

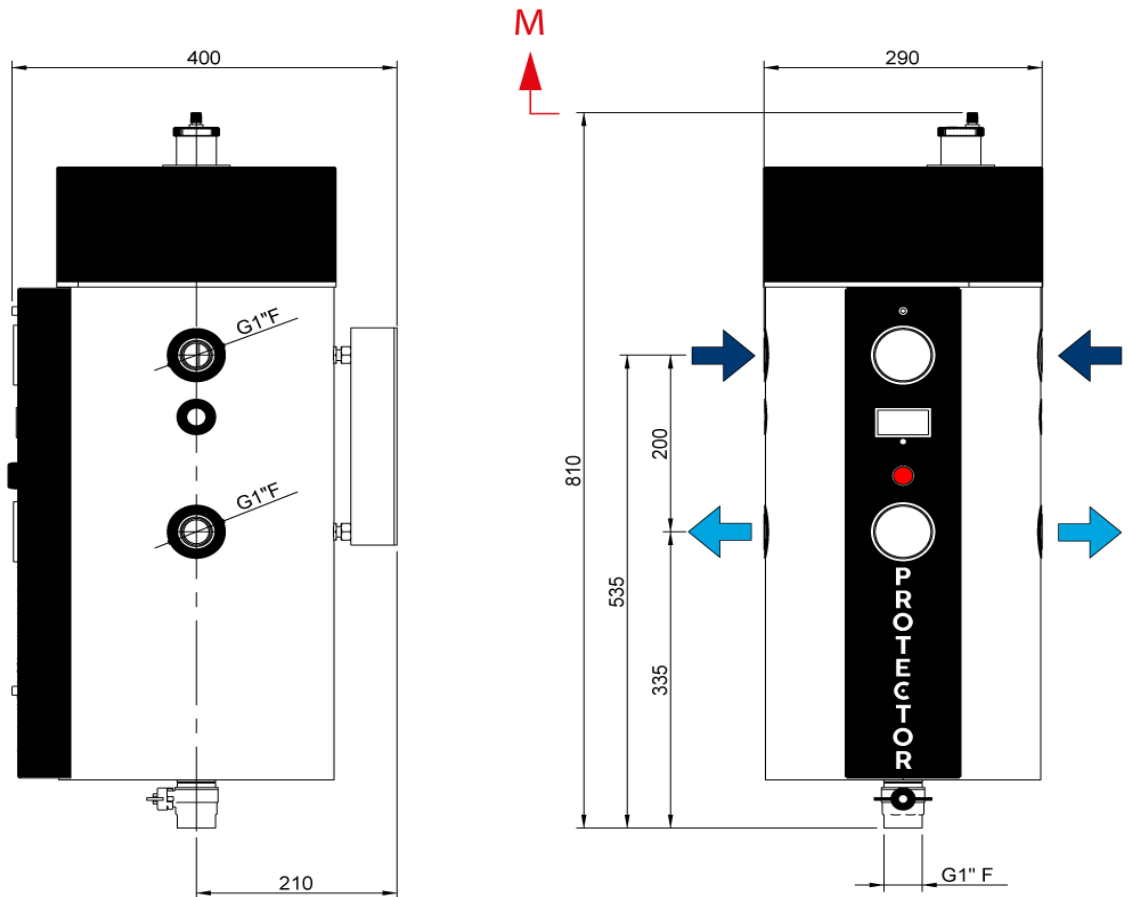

M = 500mm (Minimum free space for Maintenance)

PROTECTOR

The Complete Water Treatment System

www.protektor.no

IWTM

International water Treatment Maritime AS

Bjerkås næringspark bygg 1, PB 54

Eternitveien 34

3470 Slemmestad

Norway

Phone :+47 31 28 71 71

Info@protektor.no

www.protektor.no